



*Floral Display
Merchandisers*



FLORALWALLTM
SP-W/TS series
(with top shelf)

Natural environment floral refrigeration units



W H E N O N L Y T H E B E S T W I L L D O

FLORALWALL™ SP SERIES with top shelf

FLORALWALL™ refrigerated displays offer advanced design features that provide unmatched superiority in styling, performance and durability. Exclusive features include Floraline's patented self-watering/self-cleaning system that extends product shelf life and reduces shrink of floral bouquets and cut flowers. This industry-first feature minimizes maintenance and frees your personnel for more important tasks.

The SP-W/TS series is an open front floral merchandiser with a top shelf designed for maximum product visibility and impulse sales. These displays feature four rows to merchandise floral bouquets and cut flowers, and a PVC top shelf to display arrangements and specialty items.

STANDARD FEATURES

- Patented self-watering/self-cleaning system replenishes water automatically; keeping it fresh for floral bouquets.
- Soft Air Flow Environment. A refrigeration envelope is created by directional air flow simulating a closed-door environment. Protects even the most delicate flowers.
- Polyurethane foamed in place insulation.
- Long-lasting, high-output SPX 35 lamps for truer, more natural floral presentation.
- Under case air return.
- Charcoal-impregnated water filter system removes harmful chemicals.
- Dual air pattern for environmental control.
- 12" mirrored backwall and mirrored ends for brighter, more bountiful appearance.
- Vases sit at 15° to enhance visibility.
- Full selection of exterior laminate colors to complement your store decor.



SP-W/TS SERIES & MORE

Floraline manufactures a complete selection of open-air and closed-door floral merchandisers that complement the SP-W/TS series. Our custom-design services and cabinet department can tailor these displays for your specific requirements.

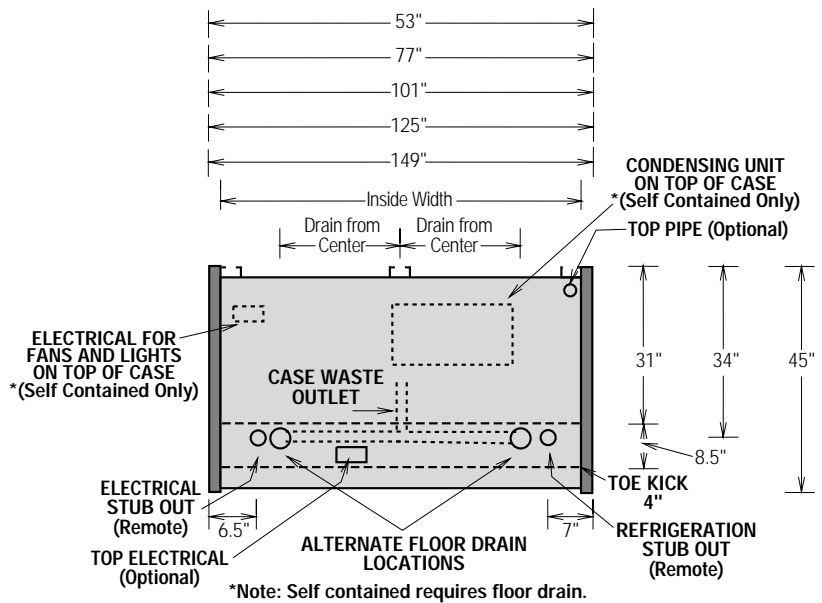
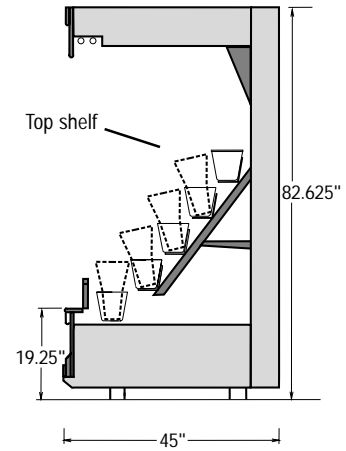

MODEL	SP4	SP6	SP8	SP10	SP12
Overall width	53"	77"	101"	125"	149"
Inside width	48.5"	72.5"	96.5"	120.5"	144.5"
Overall depth	45"	45"	45"	45"	45"
Drain from center	16"	24"	24"	24"	24"
Utilities from wall	34"	34"	34"	34"	34"
Lights Amp	1.1	1.5	2.2	2.4	3
Fans Amp (115V 1PH 60HZ)	0.5	0.5	1.1	1.1	1.5
Vases (8" center to center)	22	34	46	58	70
Capacity (3 bouquets/vase)	66	102	138	174	210
H2O Transformer AMP (Max)	3.0	3.0	3.0	3.0	3.0
BTU's@25° (R22 Standard)	5,400	8,100	10,800	13,200	16,200
Anti-Sweat AMP	N/A	N/A	N/A	N/A	N/A
Maximum Fuse Size	15	15	20	25	25
Defrosts - two 30 minutes	yes	yes	yes	yes	yes



Floraline Display Products

38160 Western Parkway • Willoughby, OH 44094
 Phone: 800.239.3722 • 440.975.9449 • Fax: 440.918.9043
 e-mail: info@floralinedisplay.com • web: www.floralinedisplay.com