

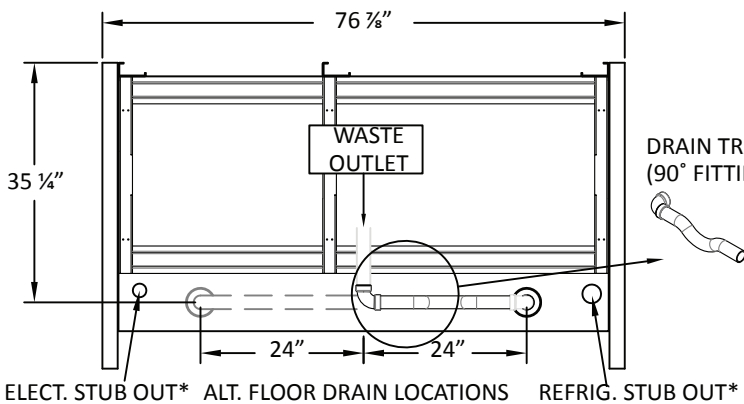

PDR- 2
Refrigerated floral reach-in display fixture

Features:

- Anthony™ or Ardco™ 2-door line-up
- Thermalpane side glass both sides
- 2' step risers with vases
- Tempered glass shelves with brackets
- Boston Bumper
- Laminate case ends
- Ball valves and setter valves
- CPC temperature sensor, inlet & outlet sensors
- One year parts warranty

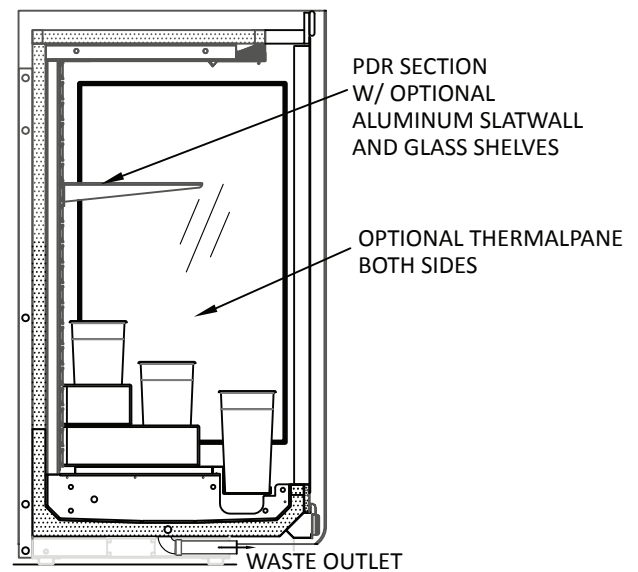
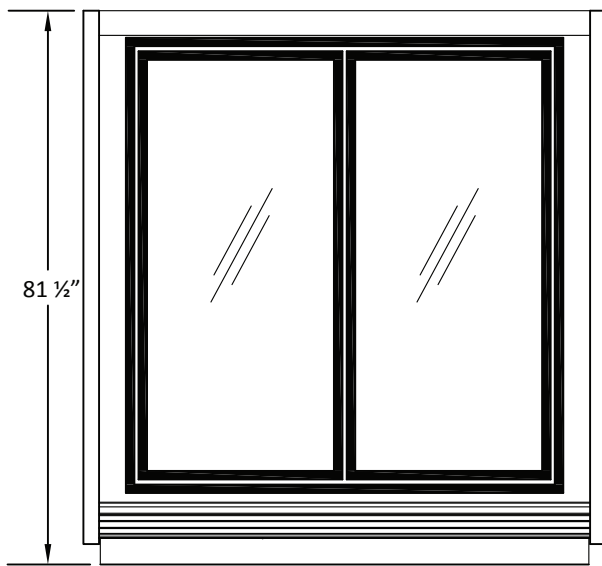

LIGHTS	1.5 AMP		PDR-2 6'	
FANS	0.5 AMP	115V	1PH	60Hz
ANTI-SWEAT	0.8 AMP			
BTUs@+25°F	3,600		R-404A STANDARD	

Floraline Display Products Corporation - www.floraline.com

38160 Western Parkway Willoughby, Ohio 44094

Phone: (440) 975-9449 or 800-239-3722

Fax: (440) 918-9043